

A **Strong and Safe Grip**

QUAD-PRESS

Permanent-electro magnetic system
for quick mold clamping

*the original
with the red grid*

Flexibility

Productivity

Quality

Safety



TECNOMAGNETE[®]
Safety through power

QUAD-PRESS®

Rapidity and uniformity of clamping



to

The strength of the Leaders

In the early '70s, Tecnomagnete was the first company to invent and offer a permanent-electro magnetic system able to perform with high power and in total safety for clamping and lifting ferrous parts of any shape and size.

The early '80s Tecnomagnete further developed this system by patenting the square pole circuit with a neutral yoke called Quadsystem.

This enabled them to manufacture permanent-electro systems more efficient and able to satisfy the various requirements of workholding for heavy duty cutting on machine tools.

During the '90s Tecnomagnete was again the first to apply such technology for quick mold clamping on plastic injection machines.

The success of an innovative technology

Quad-Press is currently the most complete answer to the growing requirements of concepts like JIT (Just In Time) and SMED (Single Minute Die Exchange) in all advanced manufacturing process to face smaller production batches and wider product ranges, by offering:

- improved manufacturing flexibility
- reduction of machine down time
- better quality in molding
- reduction of inventory
- lean manufacturing process
- practical and safe use
- higher productivity

Many thousands installations are already done all over the world on the best machine brands either new or already in use have proven the great economical convenience of the Quad-Press system in numerous industrial sectors.

Intrinsic safety

The permanent electro circuit Quadsystem made with square poles of alternating polarization North/South in a chessboard configuration guarantees the flat and horizontal circuiting of the magnetic flux concentrated exclusively in the polar area.

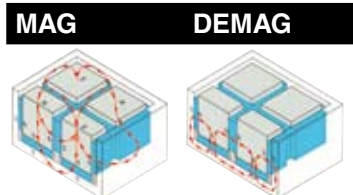

A short electric pulse lasting some fractions of second activates the system securing the clamping of the mold for unlimited time without consuming electrical energy or generating any heat. Only by a subsequent electric pulse is it possible to demagnetize the system and disengage the mold that has been held exclusively by the strength of permanent magnets during the working session.



TECNOMAGNETE®

Safety through power

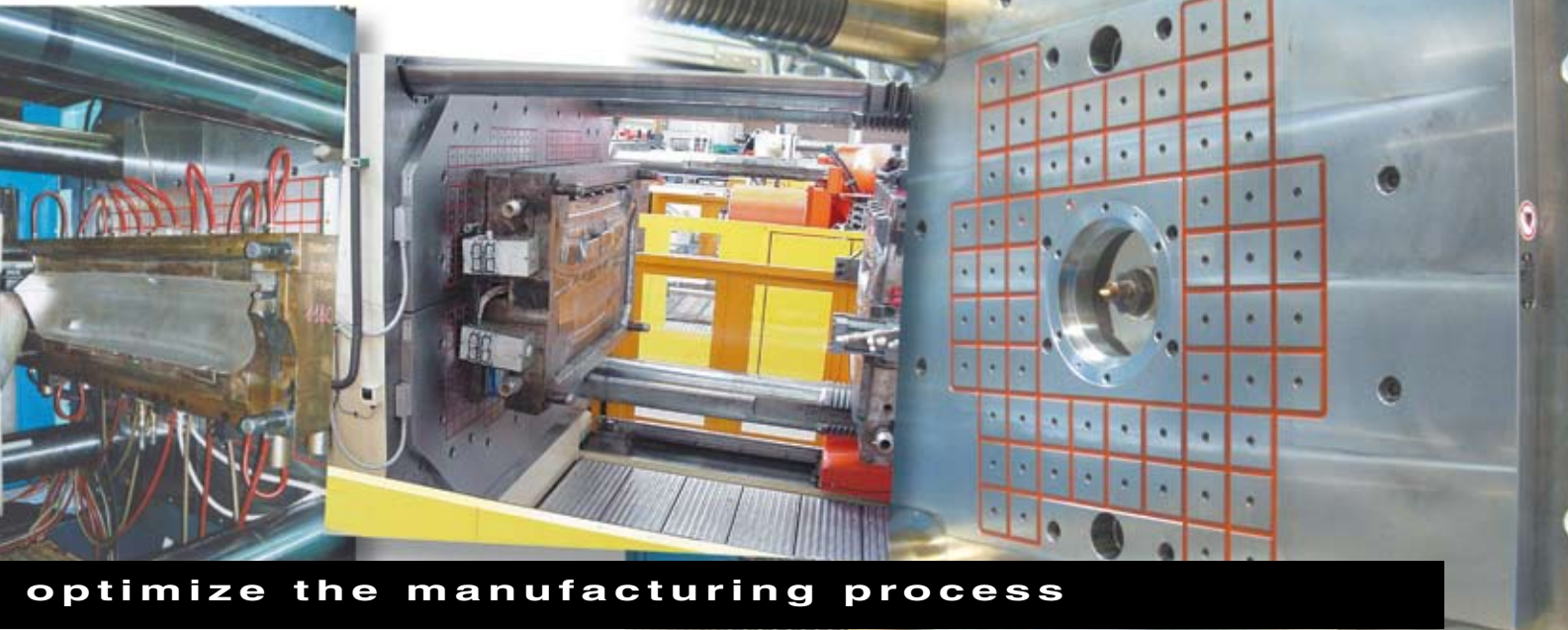

optimize the manufacturing process

Constant force

Each square pole of the Quad-Press system is an independent magnetic island made by a steel core and surrounded on its 5 faces by "high energy" permanent magnets (AlNiCo + neodymium) able to generate a high value of magneto motive force (m.m.f.) concentrated and constant at indefinite period of time. The total holding force available is directly proportional to the number of magnetic poles engaged with the surface of the mold thus always predictable.

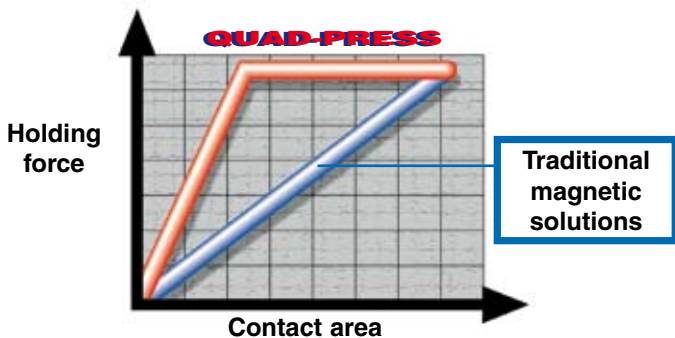

The innovative polar geometry of QuadPress can reach the maximum operating efficiency even on molds of smaller size being the polar area concentrated in the inner surface of the magnetic module corresponding almost to the size of the smallest mold acceptable by the machine.

Absolute Uniformity

A mold - when magnetically clamped - does not receive any stress or deformation as its holding strength is equally distributed across the contact area instead of the peripheral points when the traditional systems are in use which unavoidably also tends to bend with heavy molds.

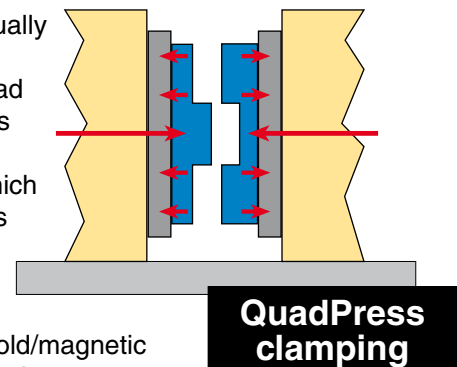

The combination of mold/magnetic module/machine platen becomes a perfect match and guarantees superior operating conditions. The absence of deflections in the mold and machine platens translates to better quality and repeatability of the molded parts.

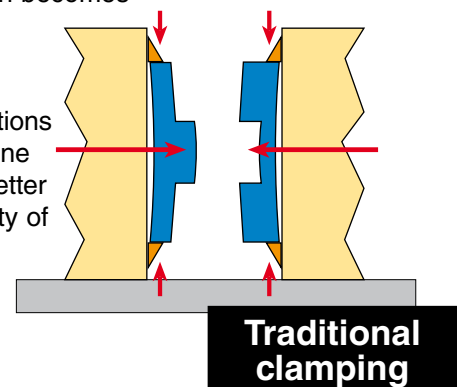

Automotive, home appliances, lighting, packaging, electronics, connectors, fittings, furniture, health care and many others industries are already successfully using Quad-Press systems on machines of any size and tonnage.

QUAD-PRESS®

A great competitive advantage

Total Flexibility

Molds of any shape and size are easily clamped without any modification of the mold base plates, even in the presence of previous QMC standardization.

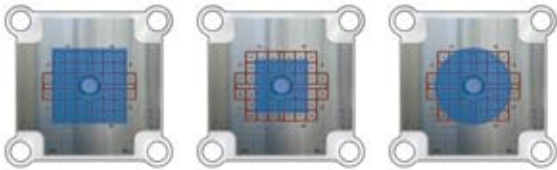

Quad-Press allows entire machine platens utilization without the constraints of the traditional mold clamps and, in some cases, the mold can even overhang increasing the press capacity.

Smaller presses can operate larger and more complex molds at higher speeds. This translates into a lower initial investment and less operating costs.

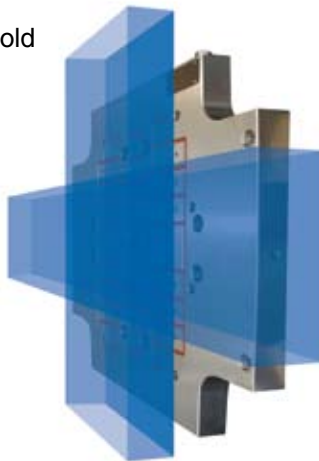

Perfect adaptability

Quad-Press can be easily and quickly installed on any press by bolting the magnetic modules to the slots or hole pattern present on the machine platens without any modification.

Quick pay-back

The competitive price combined with the high R.O.I. of the system allow to justify the investment within a few months of use.

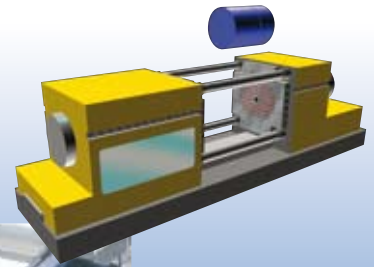

Absolu

1
Press open and mold loading.



2

Mold set up on the stationary platen by locating ring.



Ergonomical and practical

A single mold setter, without special skills, can perform the mold change standing outside the machine and away from the mold during its handling phase.



Highly cost effective

No consumption

No pollution

No maintenance

No wearing



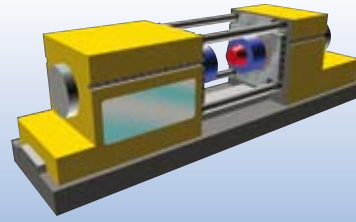
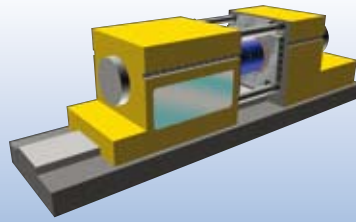
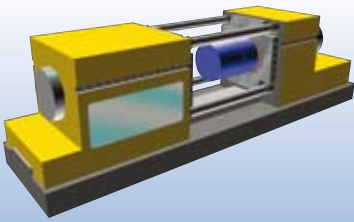

te records in safety and speed

Mold change and set up time reduced to 1/10

*Performances always
sure, repeatable and
automatically detected.*

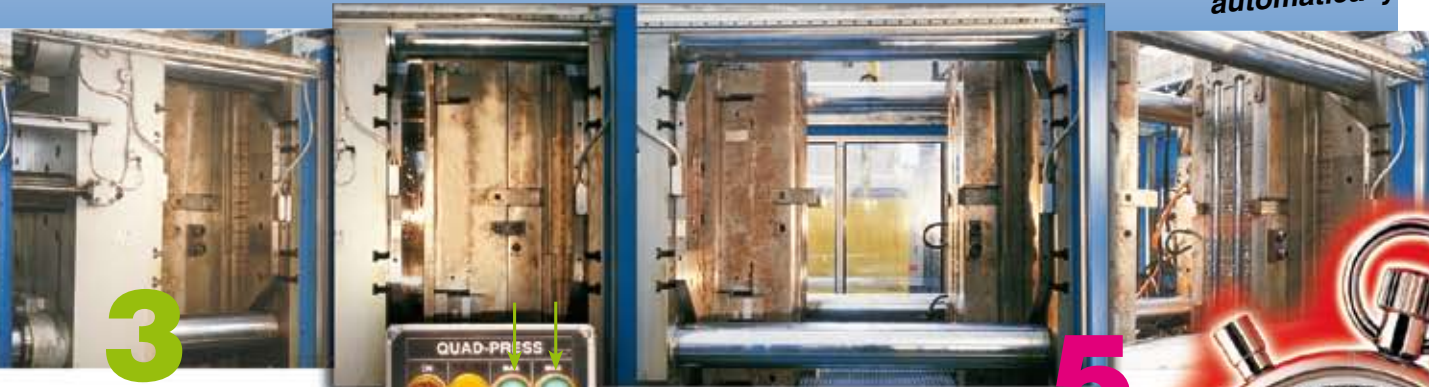

3

Press closed



4

Activation of the safety key (removable) and the MAG push button of the stationary and moving plate

5

Correct mold set up ready to work in a very short time



Easy access

Easier access and maintenance to all the "peripherals" (electrical, hydraulic, air) of the mold due to the absence

of traditional clamp encumbrances.

Reduced inventory



The implementation of the "Just in Time" manufacturing process translates into sharp reduction

of inventory with the optimization of the floor space, handling costs and time.



Scrap reduction

The quality of clamping with rapid mold changes, that helps to keep the working temperature, enhances the productivity of the machine, generates a significant reduction of non conforming parts.

Long lasting



Quad-Press prevents any damage to the machine platens. No need to re-thread any stripped holes or

resurface the surface of the platens with unavoidable loss of productivity. The machine and the magnetic modules will retain their value over the time.



Clean environment

The absence of hydraulic oil makes QuadPress the ideal solution for the production of uncontaminated parts in a clean room environment.



No additional "hidden" cost.

The only investment is the initial one.

No cost for bolts, nuts, clamps or dedicated tools and no more problems

with maintenance of the hydraulic circuit and with oil waste disposal. No maintenance of the QuadPress modules and machine platens. No loss of production.

QUAD-PRESS®

A "State of Art" manufacturing concept according to the international standards (Euromap, SPI, JIS ..)

Through holes



The monoblock frame is drilled with all the mounting holes for installation and the through holes for ejectors clearance on the moving platens.

Locating ring



For a quick and precise mold set up.

Lower resin level



Special epoxy resin with high thermal and dynamic resistance is used to seal the magnetic circuit. The under surface level positioning helps to stabilize the temperature and to avoid any possible "air-gap" in case of micro expansions.

Junction box



Machined into the monoblock Quad-Press frame becomes an integrated part without protruding elements that could be damaged and with better characteristics of resistance and waterproof.

FCS sensor



To check the value of the magnetic flux saturation reached by some pilot poles and to enable the machine cycle.

Proximity sensors



An inductive proximity sensor located in the "neutral" area detects the presence of the mold to enable the activation of the magnetization cycle. The 0,2 mm (0.0078 in) threshold value prevents any "open field magnetization" to grant the operator safety and it immediately halts the machine functions in case of mold detachment. The full safety for the operator is also granted.

Side filling blocks



Rectangular steel blocks to be bolted over the area surrounding the magnetic module to grant the full contact with the mold base. As an alternative, modular round POT blocks can be provided with magnetic fixturing for free positioning on the machine platens.



Special solutions for different applications

Solid block construction

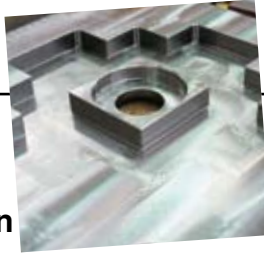

The two magnetic modules for the stationary and moving side are built with a specific milling machining out of a solid steel plate. This gives the system structural stability and durability over time.

Neutral Yoke

The Quadsystem circuit works with the "neutral yoke" principle invented by Tecnomagnete where the whole magnetic flux is concentrated exclusively in the polar area. The absence of any stray flux guarantees constant performances of the system and no trouble for the machine and mold components.

Side mold loading.

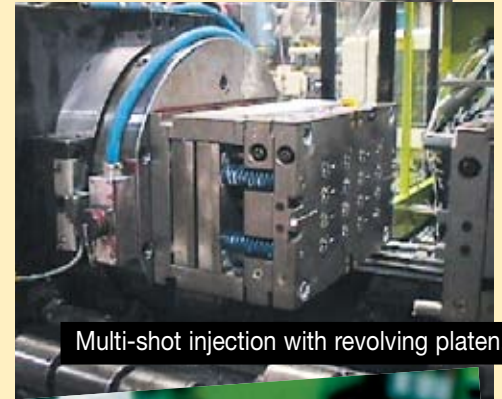

Multi-shot injection with revolving platen.



Solution for tiebarless machines.

Reduced thickness



The solid block construction besides granting a perfect planarity allows to keep a reduced thickness of the Quad-Press modules.

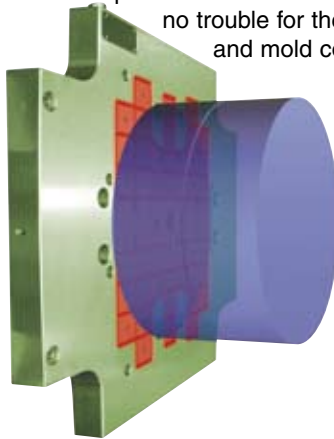

Mag phase

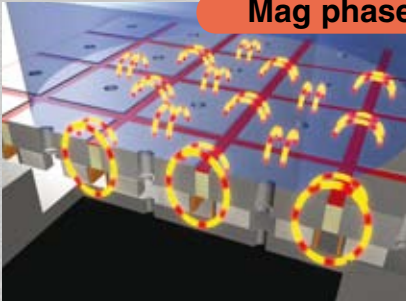

Operating phases

Magnetization

During the Mag phase the magnetic flux is short-circuited outside the magnetic surface safely clamping the mold with a very limited magnetic depth so as not to affect any internal part of the engaged mold.

DEMAG phase

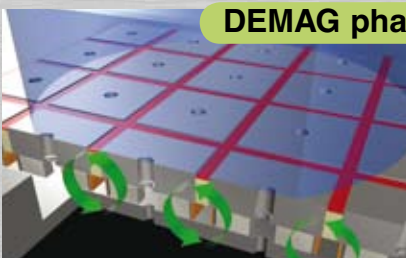

Demagnetization

During the Demag phase the magnetic flux is short circuited inside the magnetic module frame, perfectly releasing the mold for its changeover.

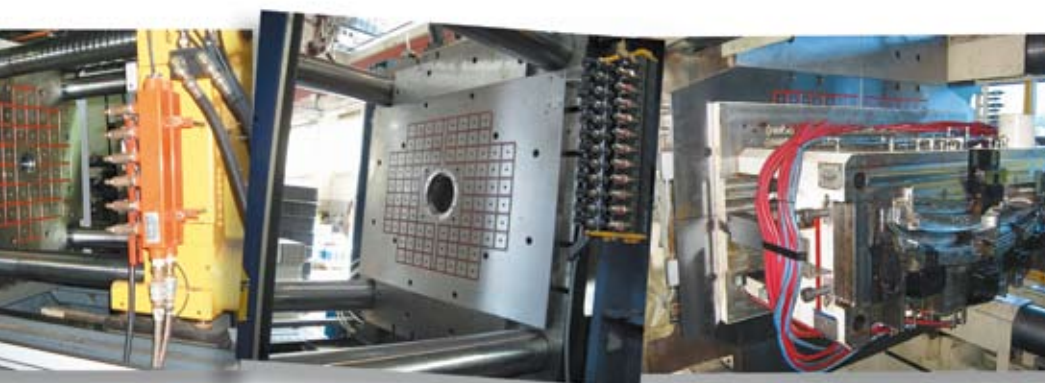

Vertical press.



Technical features and sizes

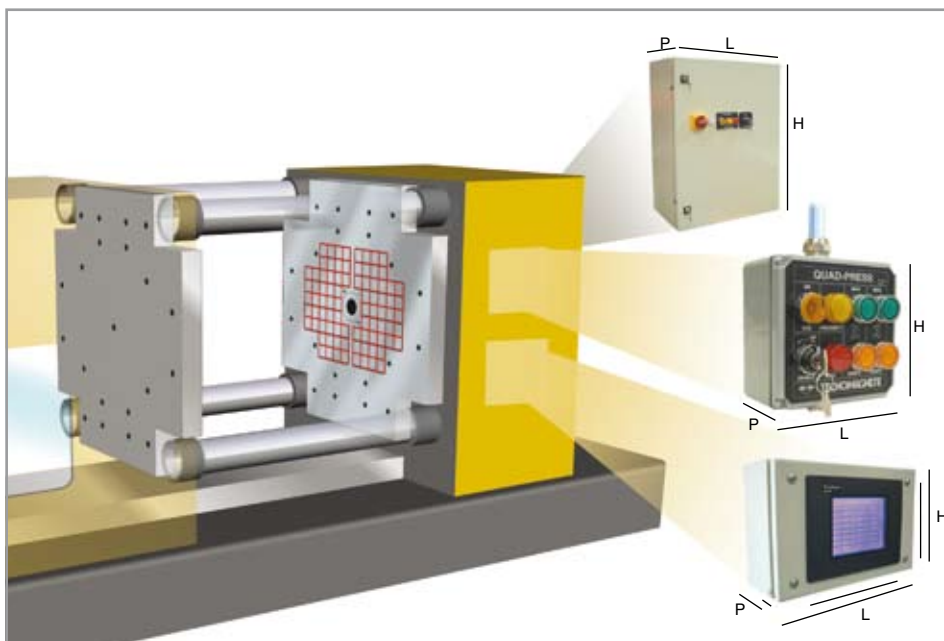

Size	L	H	P
Electrical cabinet			
<i>Machine tonnage</i>			
up to 1600 t	mm 600	600	200
	in 23.62	23.62	7.87
over	mm 1200	600	300
	in 47.24	23.62	11.81
With IPC			
	mm 500	400	200
	in 19.68	15.75	7.88
Standard push-button			
	mm 140	140	80
	in 5.51	5.51	3.15
Touch screen push-button			
	mm 211	160	80
	in 8.3	6.3	3.14
Box touch screen			
	mm 280	254	95
	in 11	10	3.75

Pull / gap curve

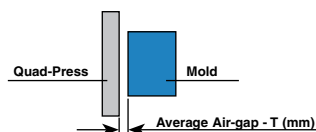
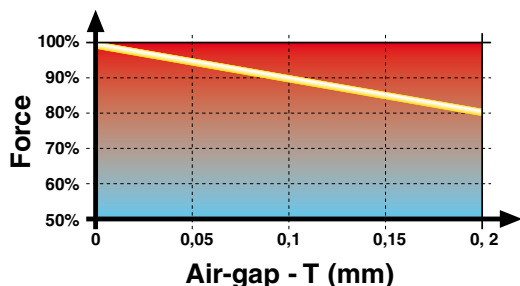

Supply specification

- QP permanent-electro magnetic modules, in steel monoblock, for fixed and moving platen, with centering ring.
- Fixing and ejectors holes, based on standard (EUROMAP / SPI / JIS).
- Electronic control unit, IP54 cabinet, provided with interface for PLC, UCS current Control Unit, FCS electronic Flux Control System.
- Remote push-button for MAG/DEMAG cycle, with signal lamps and interlock key.
- Wiring cables: control unit-modules, interface and power supply connections.
- No.1 proximity sensor for each platen installed on QP modules.
- Set of fixing bolts with nogs.
- Instruction book and TUV-CE certifications.

Optionals (for 80HC only)

IPC: Interactive power control push-button with color touch screen. THB thermal probe included.

CT: set of connectors on the cabinet for interfacing the machine/remote control (Harting) and for the QuadPress modules (FEME).

FCP: electronic control system to monitor in "real time" (process) any variation of the magnetic flux.

THB: thermal probe built in fixed side.



QUAD-PRESS Technical characteristics

Model	80HC		50HC (**)	
Magnetic strength for each pole (*)	1000 daN	2200 lb	370 daN	830 lb
Size of the square poles sides	80 mm	3.14"	50 mm	1.96"
Thickness of the module	51 mm	2.0"	35 mm	1.37"
Max working temperature (mold contact face)	120 °C	248 °F	120 °C	248 °F
Depth of magnetic flux	20 mm	0.78"	10 mm	0.39"
Proximity sensor threshold value	0,2 mm	0,0078"	0,2 mm	0,0078"
Standard voltages	200/230/400/440/480 VAC, 50/60 Hz			
Electrical input	15kVA (220V single phase) / 25kVA (380V two phase) / 32 kVA (480V)			
Fixing holes and locating ring	EUROMAP / SPI / JIS			

* The declared magnetic performance has been calculated with the full coverage of each pole, with a perfect contact (T=0), on mild steel plate.
** Suggested for small size machines.

Special solution on request

- for temperatures up to 180 °C / 356 °F (HC80) - 150 °C / 300 °F (HC50) in mold contact face (in special pole configuration)
- with magnetic lay out different from the standard
- with additional machinings/holes
- for tie bar less machines
- with rollers for mold side loading

- for multi shot press with revolving moving table including fast connectors, "anti-rotation" dummy plug and automatic drum reel for the mold sensor cable
- with additional mold proximity sensor
- for vertical molding



The electronics that combines functionality and simplicity

Electronic control unit

Designed according to the upmost recent standardizations Euromap, SPI, JIS. It can be interfaced with great flexibility both to new or existing machines. High level of integration can be achieved with those machine properly prearranged with interface signals.

The machine enable will be available only when the mold is perfectly positioned and the system magnetized. The electronic control units are standard equipped with UCS current Control and FCS Flux Control Systems. The electric panel is contained in standardized watertight cabinet IP54 rated.



Remote control

All the operating functions are activated and controlled by a dedicated remote push-button conveniently located; the mold setter oversees the whole mold change procedure from outside the machine in full safety. A specific safety key enables the "mold-set-mold" procedure and the Mag/Demag cycles.

The ultimate solution for a supply of excellence

Optional

IPC

The interactive control of strenght

The IPC system automatically detects the real work holding strength, related to the actual size of the mold, the quality of the contact area with the magnetic surface and relevant airgap, the thickness and the material of the mold base plate.

A touch screen panel shows the magnetic status of the system and all the working parameters thus enabling all the operating functions. The IPC system guides step by step the mold setter during the mold change phase for a correct set up and start.

The "help in line" automatically rejects any incorrect command and prevents the use of the machine whenever the work holding strength developed does not reach the threshold value pre set.



Based on the IPC values, the press working parameters can be adjusted - manually or automatically- to avoid the machine forces exceeding those of the magnetic system.



A safety password denies the use of unauthorized personnel by blocking any mag/demag function of the magnetic modules.

Tecnomagnete: The world of the Permanent electro Magnetism



With Tecnomagnete new solutions and new ideas come constant with new investments.

Modern manufacturing plants with innovative CNC machines and FMS systems, powerful stations of magnetization, marking laser and sophisticated measuring machines confirm the full commitment for high quality standard.

Tecnomagnete after having invented the permanent-electro magnetic "field" has been able with over 30 years activity to maintain and to increase its worldwide leadership with a wide range of high technology products distributed all over the major industrialized markets through a specialized network of direct subsidiaries and qualified distributors and with the cooperation of the most important machine builders. The unique know how, the specialized team of engineers, the use of up to date CAD/CAM systems for designing and manufacturing the products, the laboratories of research are the proof of our mission: "to accept the challenges of the ongoing globalization".

Workholding

Material Handling

Moulding and Stamping

We reserve the right to make changes connected with engineering progress.

www.tecnomagnete.com

Head office:

TECNOMAGNETE spa

Via Nerviano 31 - 20020 Lainate (MI) - Italy

Tel. +39-02.937.591, Fax +39-02.935.708.57

e-mail: info@tecnomagnete.it



TECNOMAGNETE®
Safety through power

Subsidiaries:

France	Tecnomagnete S.A.R.L.
Germany	Tecnomagnete GmbH
USA	Tecnomagnete Inc.
Japan	Tecnomagnete Ltd
China	Tecnomagnete Shanghai R.O.
Singapore	Tecnomagnete Singapore R.O.
Korea	Tecnomagnete Seoul R.O.
India	Tecnomagnete Mumbai R.O.

Distributor